

### 6.0A GLASS PASSIVATED BRIDGE RECTIFIER

#### Features

- Glass Passivated Die Construction
- Low Forward Voltage Drop
- High Current Capability
- High Reliability
- High Surge Current Capability
- Ideal for Printed Circuit Boards

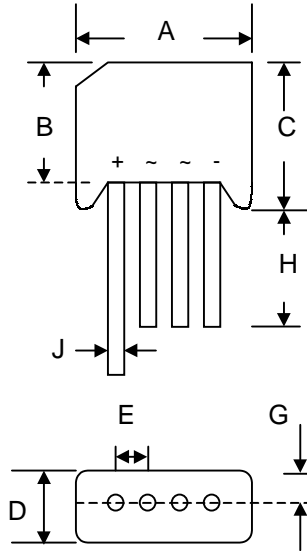

KBL		
Dim	Min	Max
A	18.50	19.50
B	13.70	14.70
C	15.20	16.30
D	4.0	6.00
E	4.60	5.60
G	—	2.10
H	16.00	—
J	0.90 Ø	1.30 Ø
All Dimensions in mm		

#### Mechanical Data

- Case: Molded Plastic
- Terminals: Plated Leads Solderable per MIL-STD-202, Method 208
- Polarity: As Marked on Body
- Weight: 5.6 grams (approx.)
- Mounting Position: Any
- Marking: Type Number
- **Lead Free: For RoHS / Lead Free Version**

#### Maximum Ratings and Electrical Characteristics @ $T_A=25^\circ\text{C}$ unless otherwise specified

Single Phase, half wave, 60Hz, resistive or inductive load.  
For capacitive load, derate current by 20%.

Characteristic	Symbol	KBL 601	KBL 602	KBL 603	KBL 604	KBL 605	KBL 606	KBL 607	Unit
Peak Repetitive Reverse Voltage	$V_{RRM}$								V
Working Peak Reverse Voltage	$V_{RWM}$	50	100	200	400	600	800	1000	
DC Blocking Voltage	$V_R$								
RMS Reverse Voltage	$V_{R(RMS)}$	35	70	140	280	420	560	700	V
Average Rectified Output Current @ $T_C = 75^\circ\text{C}$	$I_O$	6.0							A
Non-Repetitive Peak Forward Surge Current 8.3ms Single half sine-wave superimposed on rated load (JEDEC Method)	$I_{FSM}$	175							A
Forward Voltage (per element) @ $I_F = 3.0\text{A}$	$V_{FM}$	1.1							V
Peak Reverse Current @ $T_C = 25^\circ\text{C}$ At Rated DC Blocking Voltage @ $T_C = 100^\circ\text{C}$	$I_R$	5.0 1.0							$\mu\text{A}$ mA
Typical Thermal Resistance (Note 1)	$R_{\theta JC}$	16							K/W
Operating and Storage Temperature Range	$T_j, T_{STG}$	-65 to +150							$^\circ\text{C}$

Note: 1. Thermal resistance junction to case per element mounted on PC board with 13.0x13.0x0.03mm thick land areas.

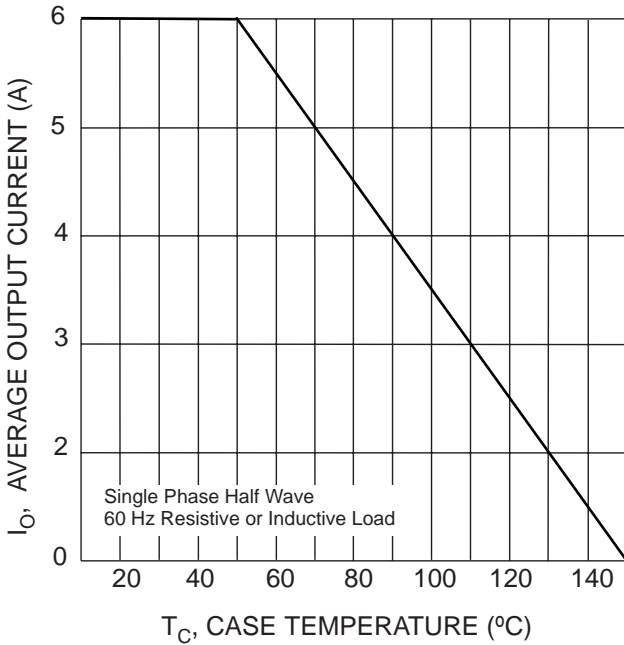

Fig. 1 Forward Current Derating Curve

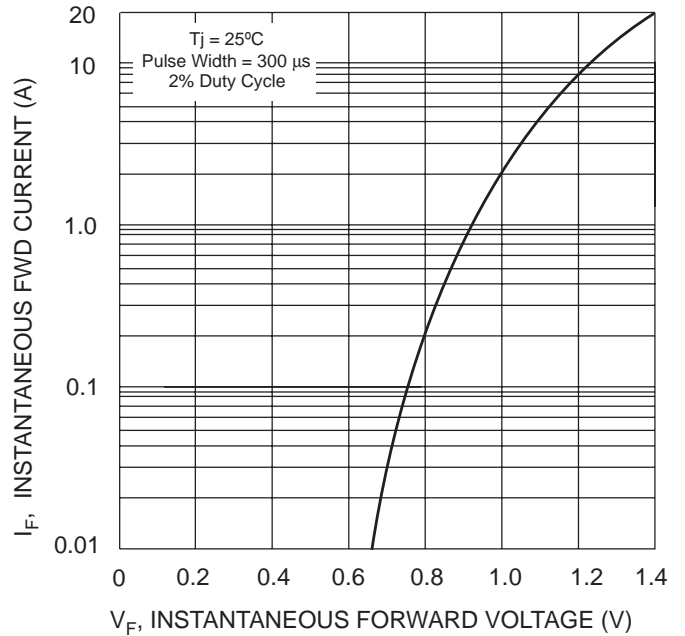

Fig. 2 Typical Forward Characteristics, per element

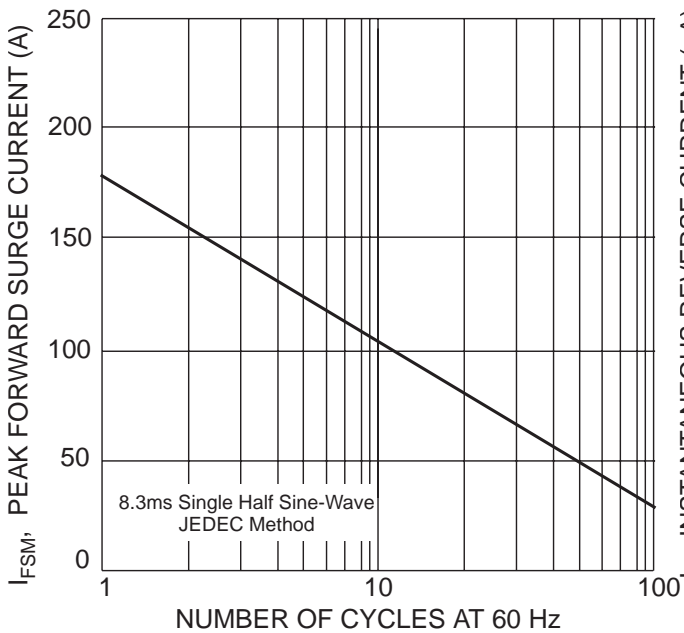

Fig. 3 Max Non-Repetitive Peak Fwd Surge Current

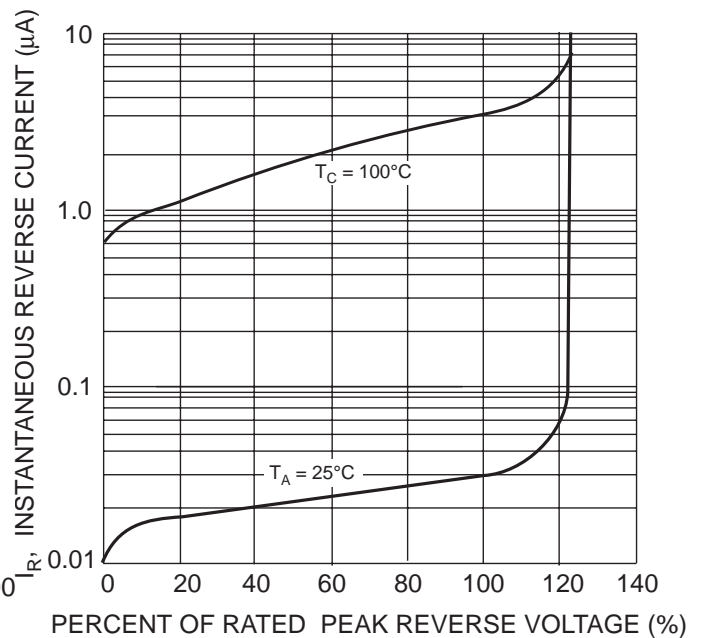

Fig. 4 Typical Reverse Characteristics, per element